

# FACTS



## HASCO

HASCO AUSTRIA GmbH – Guntramsdorf | Austria  
 HASCO Hasenclever GmbH + Co KG – Lüdenscheid | Germany

Since the establishment in 1924 in Lüdenscheid/Germany, HASCO has developed to an international and leading position for modular build standard parts and accessories. The product range contains over 100,000 products which provide individual, simple and economical solutions for tool and mould construction as well as for the plastic processing industry. HASCO delivers the entire range of ready-to-install system components including comprehensive support in application and implementation.

HASCO AUSTRIA was founded in 1969 as one of the first of today's more than 35 branches and subsidiaries. Worldwide work around 700 employees, 120 of them in Austria, to the standards of tomorrow



## BENEFITS MCC 800

- + designed for demanding serial production.
- + as a stand-alone machine or part of an interlinked production system.
- + extremely productive cash cow.
- + digital intelligence becomes reality.
- + uncompromisingly BW – in a compact machine size.
- + productive due to high flexibility even with small batch sizes.
- + very high performance for heavy roughing combined with high accuracy for fine machining.
- + also available as "multitasking machine" for turning operations.

2020:

HASCO

THE SMALL ONE GETS BIGGER – MCC 800



strong. precise. customized. digital.

# IN 2017 BW LAUNCHED THE SMALL MCC 630. THE MCC 800 IS NOW THE BIG SISTER.

In 2017 BURKHARDT+WEBER made a significant step by introducing the extraordinarily small machine model MCC 630. The machine series was completed in 2018 by presenting the larger machining centre MCC 800.

The compact machine concept of the Reutlingen-based machine manufacturer convinced HASCO, who is an international operating and leading manufacturer of standard mould units – already working with several MCC machines in their German and Austrian factories.

Amongst their machinery plant, HASCO Austria has been working with a MC60 machine model for many years which has proven to be of high quality and will continually remain in operation. HASCO clearly decided to choose BW for their new machinery investment.

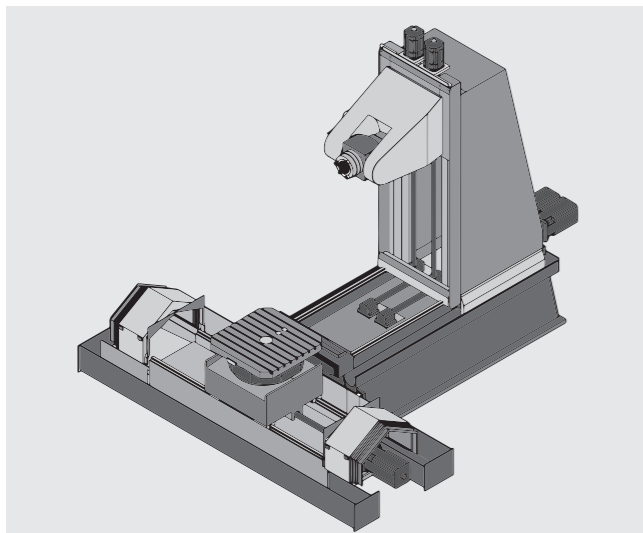

Basic construction of the MCC 800 – equipped with the "fork head" – known at BW as "A-axis".

The decision was supported by Werner Kistner, Head of the Serial Production at HASCO, who was in favour of a BW-machine. True to the motto: "It cannot be wrong to invest in proven quality." It was just suitable that BW could meet the customer's needs with the compact machine series MCC in view of the limited space capacities in premises of their installation area. HASCO set very

clear requirements when looking for a new compact machine for serial production. An older machine was to be replaced, a new one was needed. A maximum flexibility should be provided, since small batch sizes are of importance. Quick and easy retooling is an important criteria for the Austrian branch, situated near Vienna. The technical proposal between both companies was carried out simple and fast, but on the highest technical level. Two experts meeting at eye-level.

Marcos Ahorn, BW Area Sales Manager, has a special bond to the Austrian HASCO branch since his roots also lie in this central European country. "We rarely experience customers with such fixed ideas. This enabled us to proceed with the machine design more efficiently. The configuration of the standard machine was fast and uncomplicated. We were able to build on the proven HASCO modular system. As much standardization as possible, as much individualization as necessary", summarizes Ahorn the cooperation with HASCO.

Customized is what BURKHARDT+WEBER stand for. In accordance with the customer's wishes, a special design is developed for HASCO to enable an even more flexible production method. As a result, 1,000 x 1,000 mm pallet size was designed for the MCC 800, which is now the standard accessory for this machine series.

The machine produces standard parts of precision tools for injection moulding. According to customers' individual requirements, tool pallets can be machined horizontally or vertically. The added value is evident. Less retooling and easier clamping allow shorter lead times as well as higher productivity, even with batch size 1. This enables HASCO to meet short delivery time specifications in favour to their customers. The process safety plays a major role. As only a machine that is stable in the process can handle the required flexibility and the large product variety. The MCC 800 is integrated in the product-planning system. This enables a centrally controlled process of production and orders.

## 5-axis system

The MCC 800 A was equipped with a so-called "fork head". This fifth axis is known as the A-axis at BW and provides the letter "A" in the machine designation.

The fifth axis of the MCC machine series is available as standard and continuous axis and is therefore also very suitable for the machining of highly complex workpiece profiles in combined movement with the other axis. Rather unusual however, at HASCO, this fifth axis operates as positioning axis only. This is because the parts to be machined are especially demanding when it comes to high-precision gauge blocks between the bores, the rectangularity, flatness or the demand on surface quality.

The pallets shall be machined on the machining centre, without further clamping or machining on several machines in order to avoid loss of accuracy and long set-up times. This requires the machine to have a very high performance for very productive roughing and very high accuracy for the most demanding finishing operations. The MCC masters these challenges like no other in its category.

Elfriede Hell, CEO of HASCO Austria GmbH, is pleased with the cooperation of her staff with the Swabian manufacturer and furthermore that colleagues from the headquarters in Lüdenscheid also benefit from working with two BW machining centers. The machine configuration was adjusted to the local needs and in part, a special tool measuring system in the machining area was developed. An extensive amount of ideas and long-term know-how at BW for customized solutions as well as a wide range of products and various options, convinced HASCO to carry out this project.

A further advantage as a result of already working with a BW machine: the highly skilled machine operators at HASCO only had to learn specific functions of the new control unit, thus the MCC could be easily taken into operation.

The Area Sales Manager delights the customer with BW-honey instead of a traditional Vienna Sacher cake. Besides technical aspects, both HASCO and BW know about the importance of sustainable actions, both for long-term economical processes and also to fulfil a duty for future generations. "The BW-bees are our little contribution towards biological biodiversity. Furthermore, we donate the money we take in from selling our honey to local institutions", states Marcos Ahorn.



The HASCO special production even faster, more precise and more flexible by using the MCC 800 A.

The development of the MCC machine series was one of the reasons why BW won the Top Innovator 2020 award.

